

BGA 82, 96, 103,  
105

PKG code	Maximum storage capacity			PKG code	Maximum storage capacity		
	pcs/tray	pcs/inner box	pcs/outer box		pcs/tray	pcs/inner box	pcs/outer box
BGA-82P-M01	490	4900	19600	BGA-96P-M07	490	4900	19600
BGA-96P-M03	490	4900	19600	BGA-103P-M04	490	4900	19600
BGA-96P-M04	490	4900	19600	BGA-105P-M02	490	4900	19600
BGA-96P-M05	490	4900	19600				

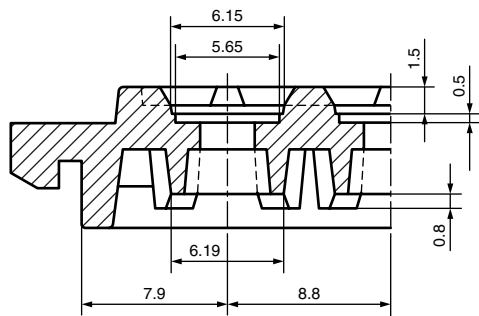

SEC. A-A

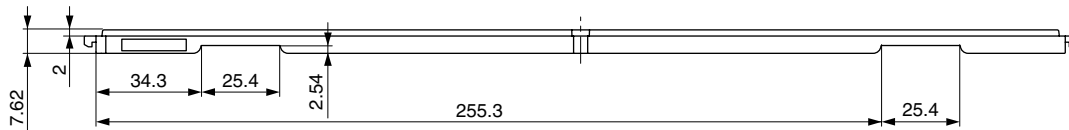
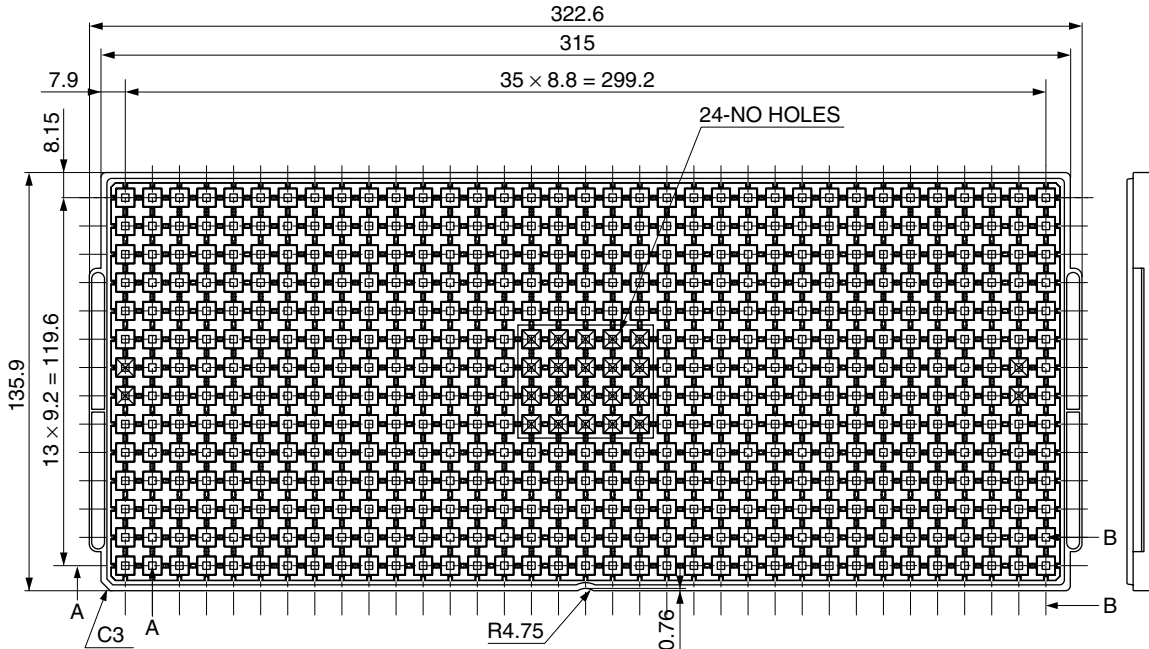
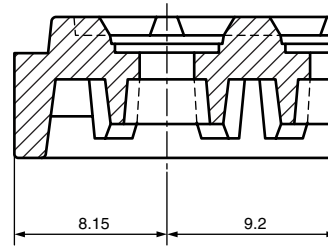

SEC. B-B

©2006-2008 FUJITSU MICROELECTRONICS LIMITED CSP6x6 : SL-BG060615TJ-2-1-Y-2

(Dimensions in mm)

Material : Conductive polyphenyleneether  
Heat proof temperature : 150 °C Max  
Weight : 162 g