

**FPT-144P-M12**

<p>144-pin plastic LQFP</p>  <p>(FPT-144P-M12)</p>	Lead pitch	0.40 mm
	Package width × package length	16.0 × 16.0 mm
	Lead shape	Gullwing
	Sealing method	Plastic mold
	Mounting height	1.70 mm MAX
	Weight	0.88 g
	Code (Reference)	P-LFQFP144-16×16-0.40

144-pin plastic LQFP (FPT-144P-M12)

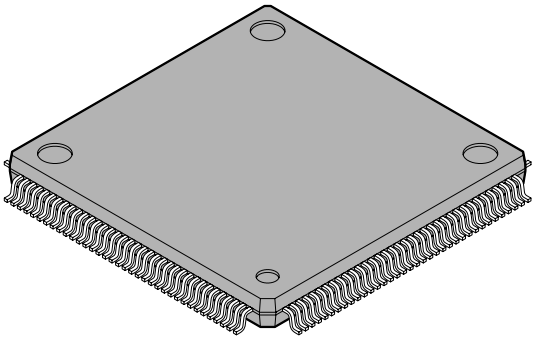
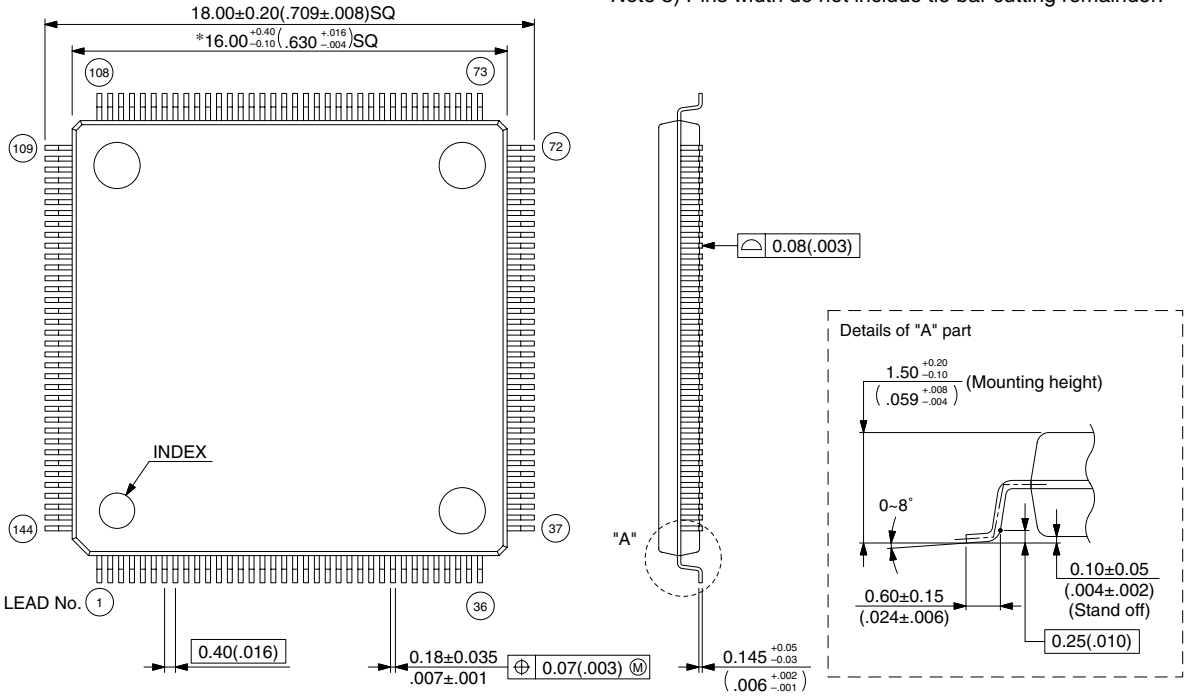

Note 1) \* : These dimensions include resin protrusion.  
Resin protrusion is +0.25(.010)Max(each side).

Note 2) Pins width and pins thickness include plating thickness.

Note 3) Pins width do not include tie bar cutting remainder.

©2003-2008 FUJITSU MICROELECTRONICS LIMITED F144024S-c-3-4

Dimensions in mm (inches).  
Note: The values in parentheses are reference values.

The contents of this document are subject to change without notice.  
Customers are advised to consult with FUJITSU MICROELECTRONICS (FML) sales representatives before ordering.  
FML is unable to assume responsibility for infringement of any patent rights or other rights of third parties arising from the use of the information or package dimensions in this document.